

ROLLED EROSION CONTROL PRODUCTS

STAKING PATTERN GUIDE

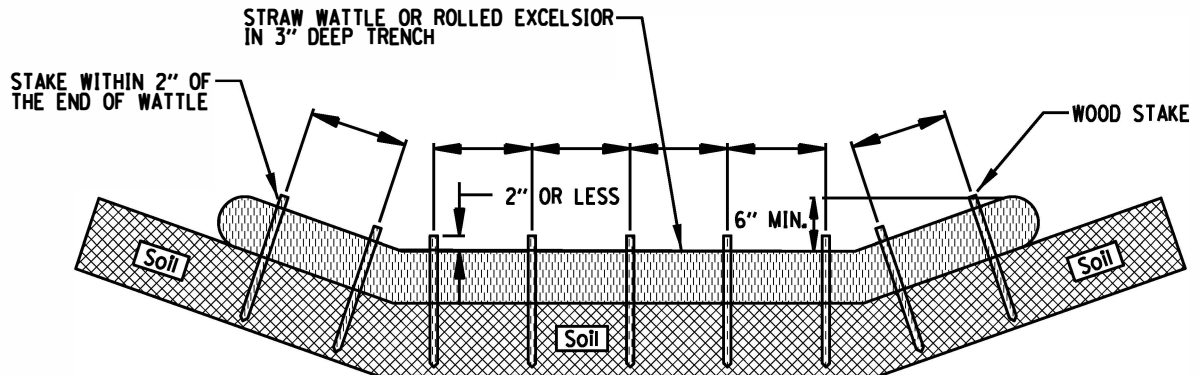

NOTES:

1. OVERLAP MINIMUM IS THE DIAMETER OF THE ROLL.
2. 4' SPACING FOR WATTLES.
3. 2' SPACING FOR ROLLED EXCELSIOR.
4. OR SPACE ACCORDING TO MANUFACTURER'S SPECIFICATIONS.

STAKE DETAIL

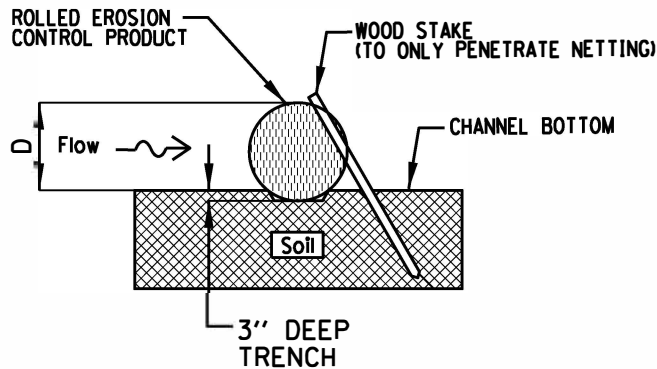

NOTES:

1. DRAWINGS ARE NOT TO SCALE.
2. ENDS OF WATTLES OR ROLLED EXCELSIOR SHALL BE TURNED AT LEAST 6" UPSLOPE.
3. RECOMMENDED STAKES ARE 1 1/8" WIDE x 1 1/8" THICK x 30" LONG.
4. STAKES SHALL NOT EXTEND ABOVE THE STRAW WATTLE MORE THAN 2".
5. SPACING: THE TOE OF THE UPSTREAM DITCH CHECK SHALL CREATE A HORIZONTAL LINE WITH THE TOP OF THE DOWNSTREAM DITCH CHECK.

REFERENCE

Project _____
 Designed _____ Date _____
 Checked _____ Date _____
 Approved _____ Date _____



STANDARD DWG. NO.

IUM-514

SHEET 1 OF 1

DATE 08-2-2019